



PERFORATION TYPES OF CLIP IN SUBSTRUCTURE SUSPENDED CEILING CLIP IN TILES

One of the most important advantages of metal ceiling systems is sound absorption which is achieved by perforation, combined with acoustic paper which is applied on the back of the tile. Equally important is the aesthetic effect which the perforation types offer.

Perforation types

1) Perforation type P – 1,8

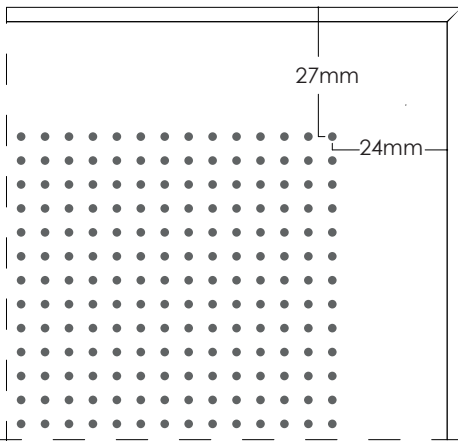

Hole mm	Perforation angle	% Percentage of perforation
1.8mm	45°	11%



Available in central perforation

2) Perforation type D – 1,8

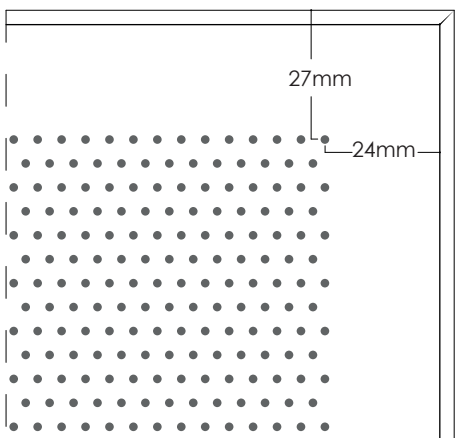

Hole mm	Perforation angle	% Percentage of perforation
1.8mm	45°	21%



3) Perforation type P - 2,5

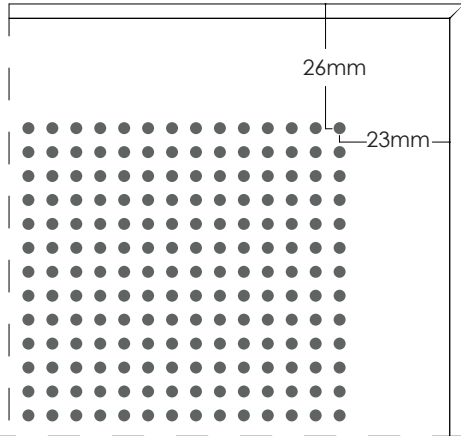

Hole mm	Perforation angle	% Percentage of perforation
2.5mm	45°	20%

*Available in central perforation

Acoustic nonwooven

Type	Coefficient sound absorption	Class	Combustion behavior	Color
R 6/60 FF	$\alpha_w = 0.75$ *	C	F1 (DIN 53438)**	Black

*Coefficient sound absorption is depended by the diameter and the arrangement of holes.

**Self-extinguishing

